



# Alumil SOLAR

## **H2300 - CUSTOM**

TECHNICAL MANUAL

Version:05.23



# Assembly Instructions

## ❖ CONTENTS

A.	MATERIAL LIST.....	3
1.	Aluminum Profiles .....	3
2.	Fasteners & other accessories.....	4
➤	Accessories needed to mount the profiles .....	4
➤	Accessories needed to mount PV panels to the structure.....	5
➤	Accessories for anchoring a base in concrete (optional) .....	6
3.	Tooling set .....	7
4.	Nut’s torques .....	8
5.	Safety zones.....	8
B.	ASSEMBLY INSTRUCTIONS FOR CUSTOM MOUNTING DESIGN.....	9
1.	CUSTOM DESIGN .....	9
➤	Placing Base Plate .....	9
➤	Modification of inclined beams (optional).....	13
➤	Mounting Connectors with inclined beam .....	16
➤	Mounting Brackets with Base Plates and the Inclined Beam .....	17
➤	Placing purlins on inclined beam .....	19
➤	Connecting Purlins Together Using Cores.....	20
➤	Mounting panel.....	22
➤	Placing end cups for Purlins and Inclined Beams.....	24
➤	Mounting Windshields (optional) .....	25
C.	MAINTENANCE .....	29

## A. MATERIAL LIST

### 1. Aluminum Profiles



BASE PLATE  
(EX-8960280100)



CONNECTOR WITH INCLINED BEAM  
(EX-8960950000)

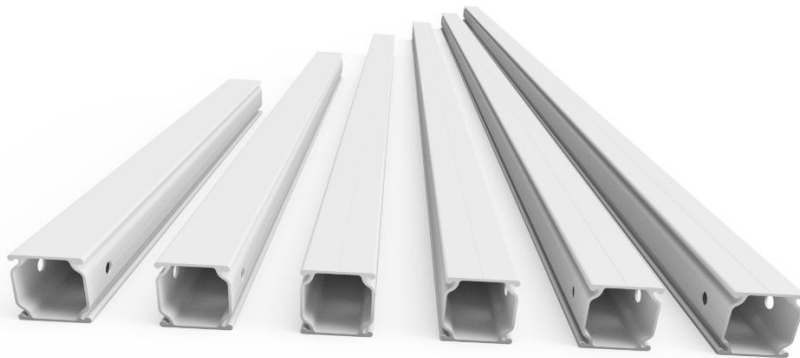

BRACKETS: Standardized Lengths



PURLIN AND INCLINED BEAM: PROFILE H2060

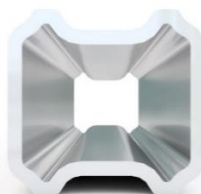

CORE FOR PURLIN AND INCLINED BEAM  
(EX-8960610310)



WINDSHIELDS

<b>BRACKETS</b>	<b>Lengths</b>
<i>EX-8963200300</i>	<i>300mm</i>
<i>EX-8963200600</i>	<i>600mm</i>
<i>EX-8963200900</i>	<i>900mm</i>
<i>EX-8963201200</i>	<i>1200mm</i>
<i>EX-8963201500</i>	<i>1500mm</i>
<i>EX-8963201800</i>	<i>1800mm</i>
<i>EX-8963202100</i>	<i>2100mm</i>
<i>EX-8963202400</i>	<i>2400mm</i>

## 2. Fasteners & other accessories.

### ➤ Accessories needed to mount the profiles



HEXAGON BOLT ISO4017 M10x80 A2 INOX  
(EX-7622108001)

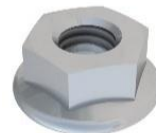

HEXAGON NUT DIN6923 M10 WITH SERRATION INOX  
(EX-8968010201)



HAMMER HEAD BOLT WITH EPDM M8x22 INOX A2  
(EX-8969122081)

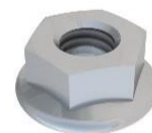

HEXAGON NUT DIN6923 M8 WITH SERRATION INOX  
(EX-8968808201)



DIN 7504-K SELF DRILLING SCREW 5,5x19 A2 INOX  
(EX-7626701901)



COMPRESSION PLATE SMALL 40mm  
(EX-8960260000)



END CAP FOR H2060 PROFILE-YELLOW  
(EX-8960600040)

➤ **Accessories needed to mount PV panels to the structure**

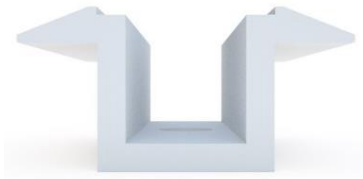

MID CLAMP PANEL  
(EX-8960180200)



END CLAMP LENGTH : X mm\*  
\*Height of end clamp depends on the thickness of the PV panel



SERRATED LOCK WASHER DIN6798-A M8 A2 INOX  
(EX-7627300801)

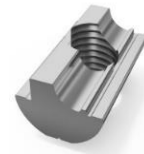

T-SLOT NUT M8 ALUMINUM  
(EX-8968008103)



ALLEN BOLT DIN912/ISO4762 M8xLENGTH INOX A2\*  
\*Length of allen bolt depends on the thickness of the PV panel



CAP OF PANEL GRIP WITH 55mm LENGTH  
(EX-8960660000)

<b>Panel thickness (mm)</b>	<b>End clamp</b>	<b>Allen bolt</b>
50	EX-8960330100	EX-7629085001
46	EX-8960430100	EX-7629084501
42	EX-8960340100	EX-7629084001
40	EX-8960440100	EX-7629084001
38	EX-8960720100	EX-7629084001
35	EX-8960450100	EX-7629083501
34	EX-8960460100	EX-7629083001
32	EX-8960621100	EX-7629083001
30	EX-8960630100	EX-7629083001

➤ **Accessories for anchoring a base in concrete (optional)**

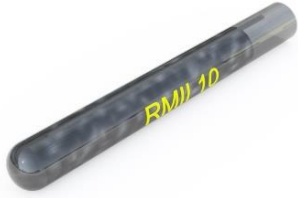

RESIN CAPSULE RM II 10  
(7300000500)



THREADED ROD RG M10x130  
(7300000510)



NUT M10



WASHER 10.5

### 3. Tooling set



Spirit Level (2m)



Stell Tape Measure (50 -100m)



Spanners Sockets (Metric)

Torque Wrench



Screw Rivet Tool



Suitable Angular Measuring Device

String Line



Tap screw adaptor



Power Driver & Bits  
Impact Driver



#### Health & Safety

It is the installer's responsibility that their personnel ensure that safe working practices as required by the site specific contract are adopted and achieved at all times. No operation should cause danger to employer, employee, contractor, sub-contractor or any member of the public.

#### 4. Nut's torques

The table below represents the specific torques that should be used for fastening the screws and nut's, according to size (i.e. M8 or M10) and aluminum's finishing (i.e. mill finished or anodized).

<b>SCREW TIGHTENING TORQUES (MILL FINISHED PROFILES)</b>		
<b>M10</b>	<b>M8</b>	<b>M8 Allen</b>
T=40-45 Nm	T=25 Nm	T = 9 - 10Nm (for thin film panels) T =12-15 Nm (for poly panels)
<b>SCREW TIGHTENING TORQUES (ANODISED PROFILES)</b>		
<b>M10</b>	<b>M8</b>	<b>M8 Allen</b>
T=50 Nm	T=25-30 Nm	T = 9 –11 Nm (for thin film panels) T =14–17 Nm (for poly panels)

#### 5. Safety zones

Safety distances of 10% roofs length should be kept from all edges of the roofs. Installation of PV panels at zones B & C should be avoided since wind forces are very high at those zones.

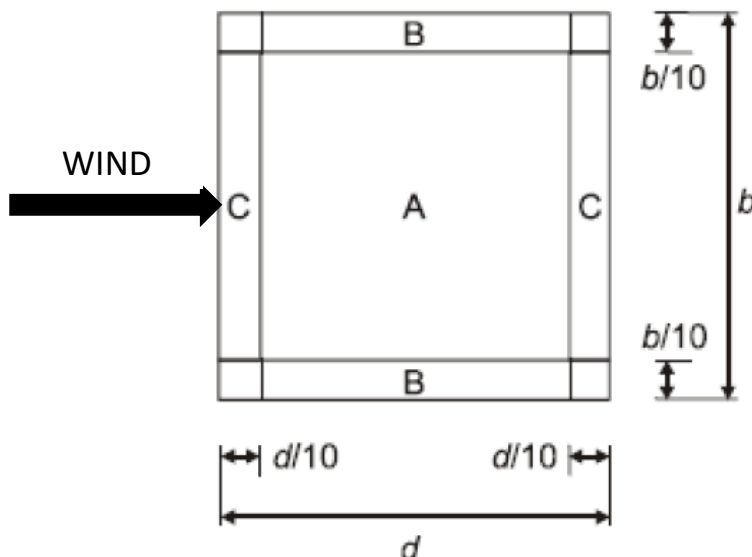



## B. ASSEMBLY INSTRUCTIONS FOR CUSTOM MOUNTING DESIGN

### 1. CUSTOM DESIGN

#### ➤ Placing Base Plate

Determine the placement of the base plates according to the Shop Drawings or instructions from the customer support. Locate the specific positions where the base plates are to be placed using the provided X and Y dimensions as reference points for their accurate placement.

Transfer the X and Y dimensions from the shopping drawing onto the installation site and mark the precise hole locations for each base plate.

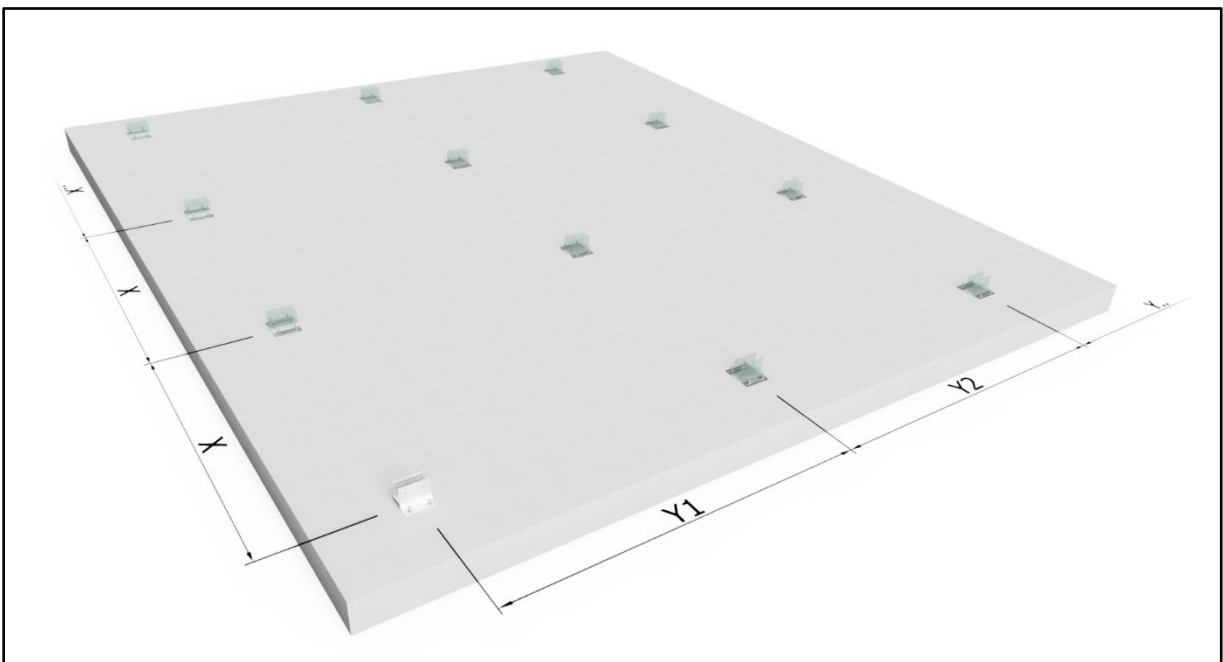

Begin drilling the hole, making sure to keep the drill straight and steady. Pay attention to the drill's speed and pressure to avoid damaging the roof material. Specified drill hole depth 90mm should be adhered to drill the hole.

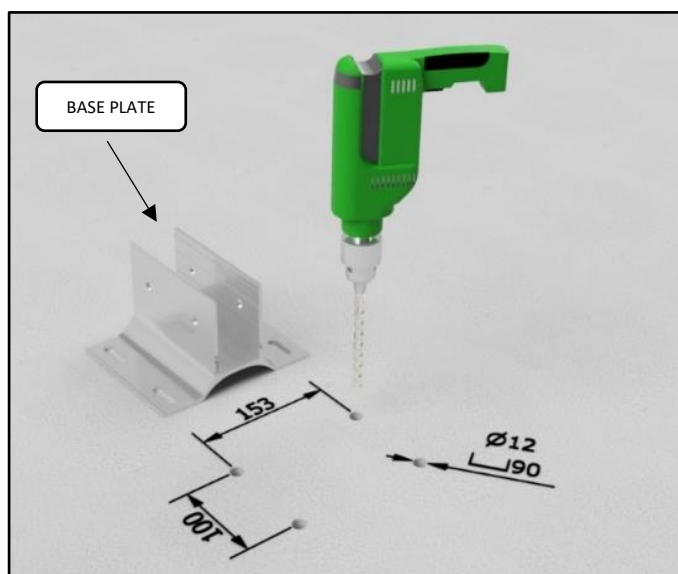

When reaching the drill hole depth 90mm pull out the drill bit whilst power drill is switched on. To reduce the drill dust in the drill hole, repeat this step minimum three times, beginning from the drill hole bottom.

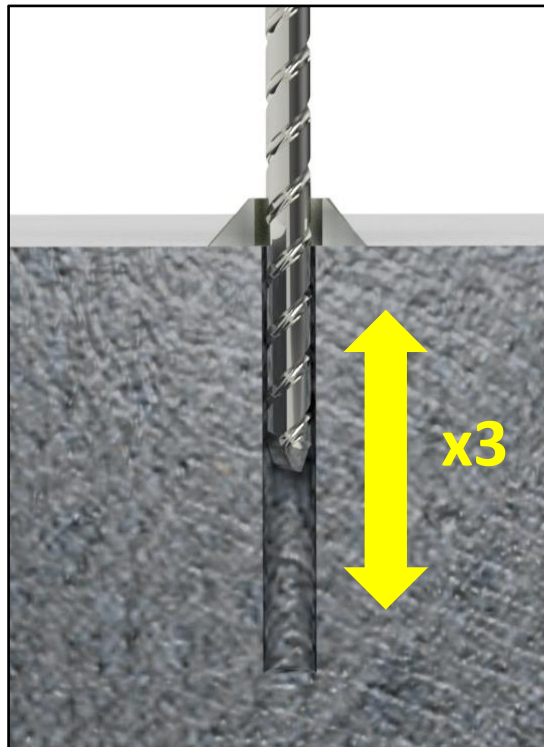

Trickling of the bore dust into the drill hole must be avoided. (e.g., with exhausting the drill dust). Blowing out or brushing the drill hole is not necessary.



Push the capsule RM II 10 into the drill hole.

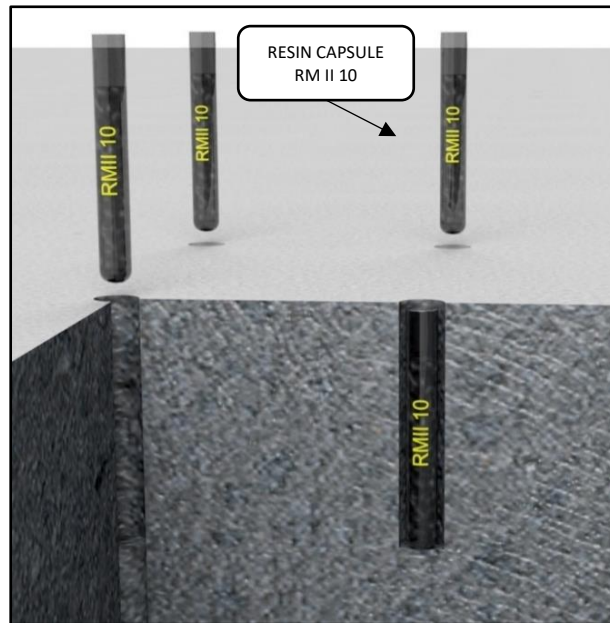

Only use clean and oil-free metal parts. Using a suitable adapter, drive the RG M into the capsule using a hammer drill set with a rotary hammer action. Stop when the metal part reaches the bottom of the hole and is set to the correct embedment depth.

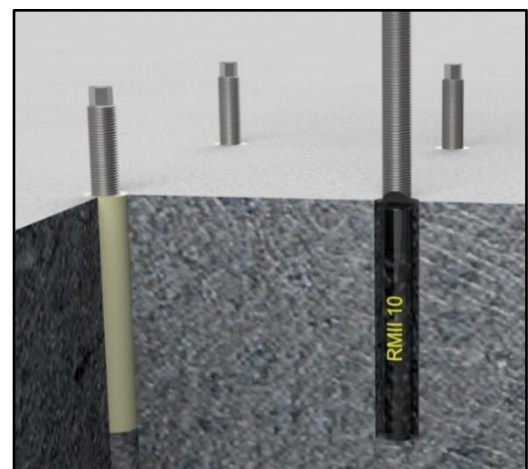
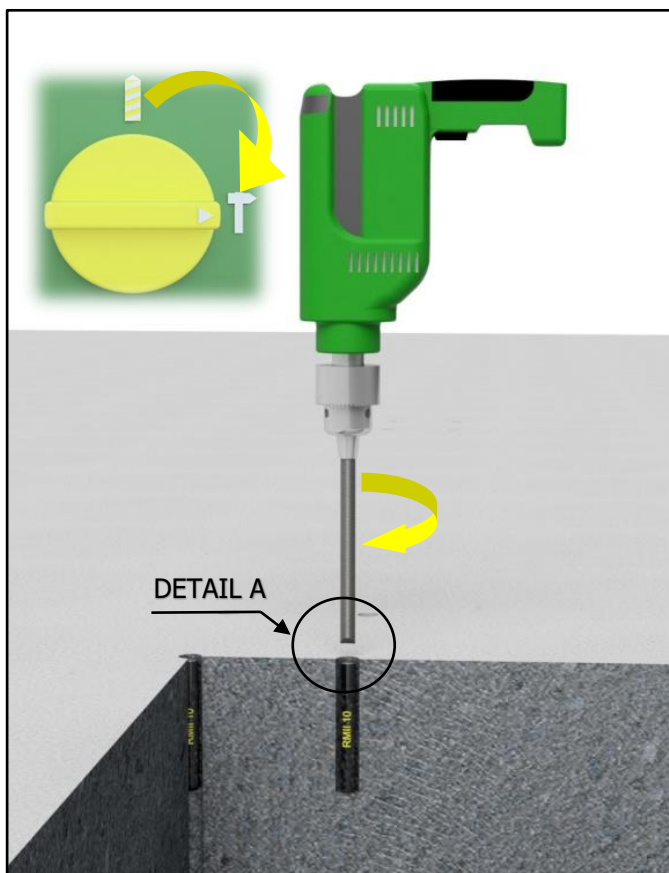

DETAIL A

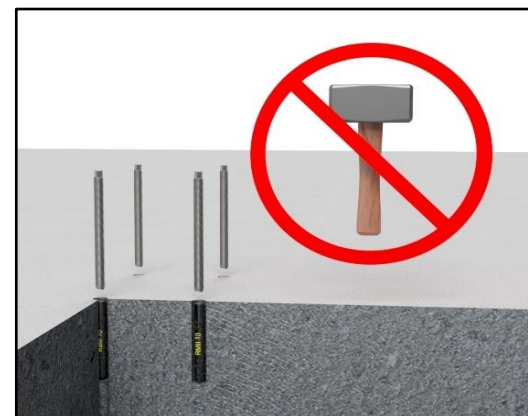

When the correct embedment depth is reached, the excess mortar should come out of the hole mouth.

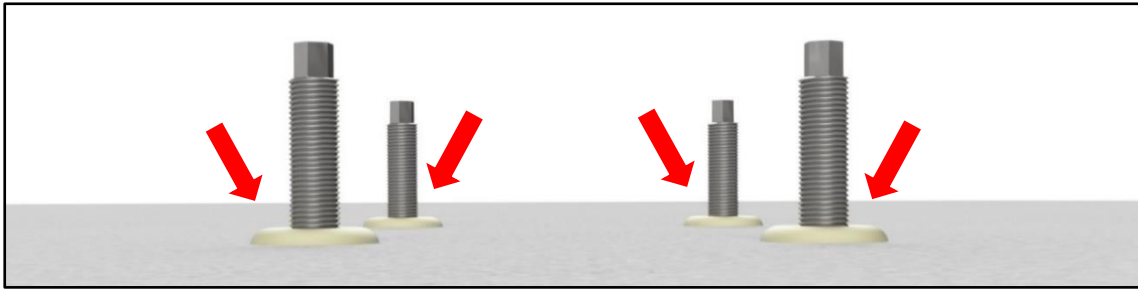

Note: It is important to follow all safety guidelines and wear proper personal protective equipment when drilling holes in a roof. Always consult the roofing material manufacturer's specifications and guidelines before drilling a hole.

Anchor the base plate securely to the ground.

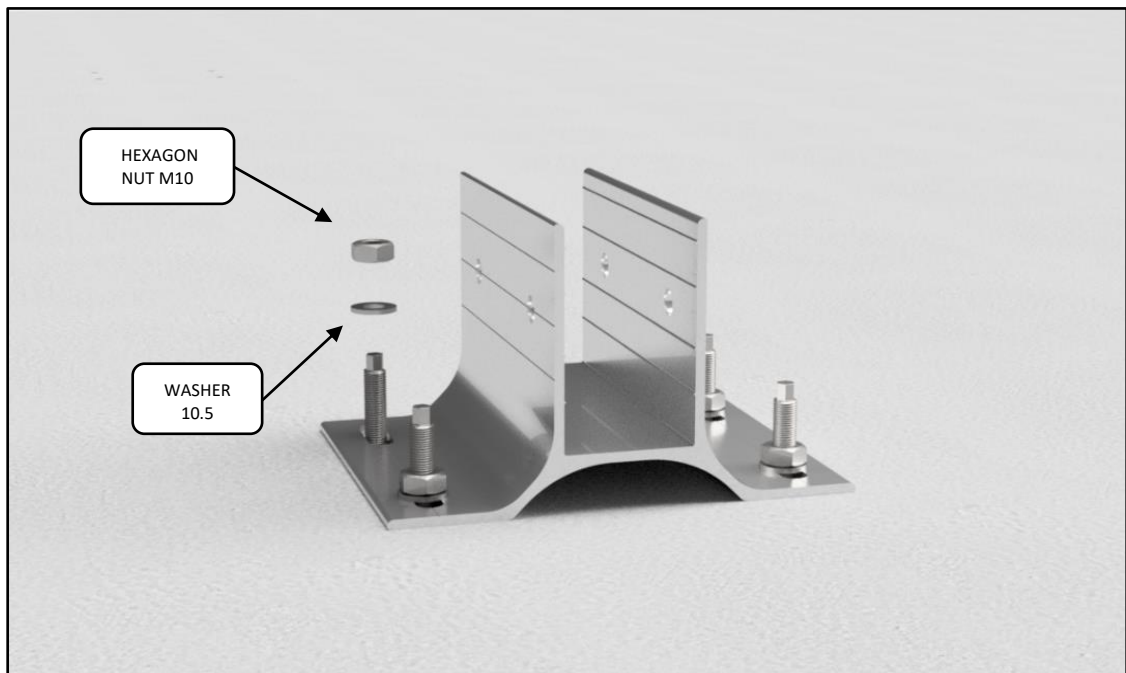

➤ **Modification of inclined beams (optional)**

In some cases, the inclined beams provided may need modification to suit the specific requirements of the project.

Depending on the dimensions specified in the project drawings, it may be necessary to cut the inclined beams to the appropriate length. Ensure precise measurement and use suitable cutting tools to achieve the desired length.

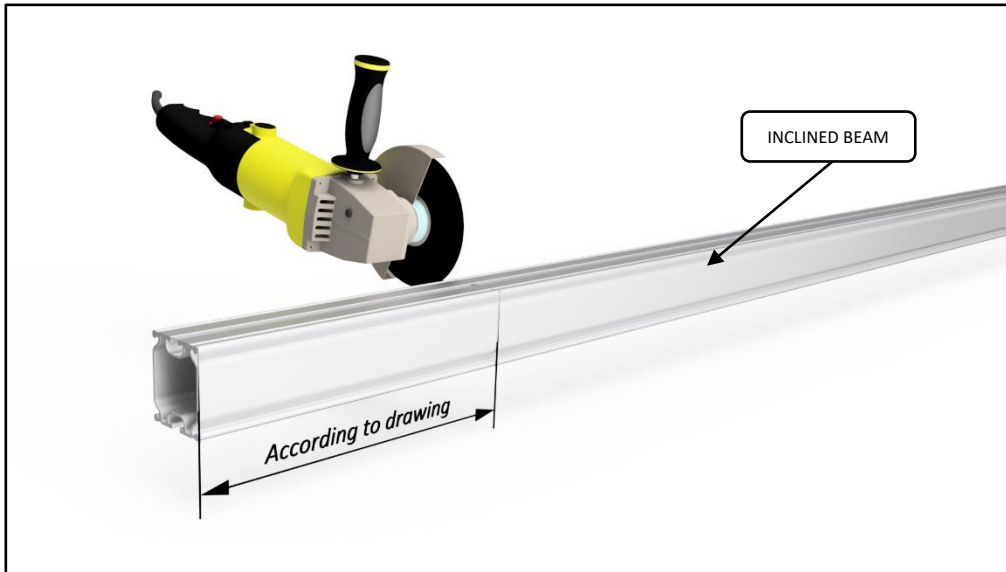

If longer lengths are required, it is necessary to connect two inclined beams together. This can be done by using a core and two Self-Drilling Screws 5.5x19mm, with one screw on each side of the joint

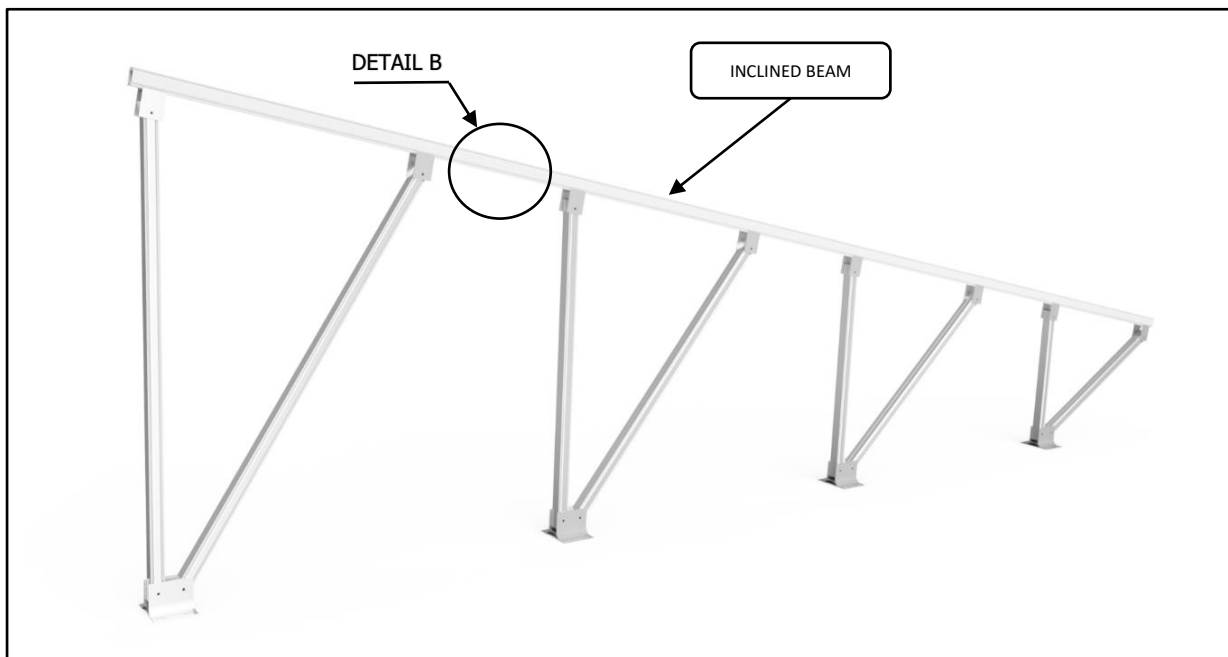

Place the core in the 2 successive Beams and mount with 2 self-drilling screw.

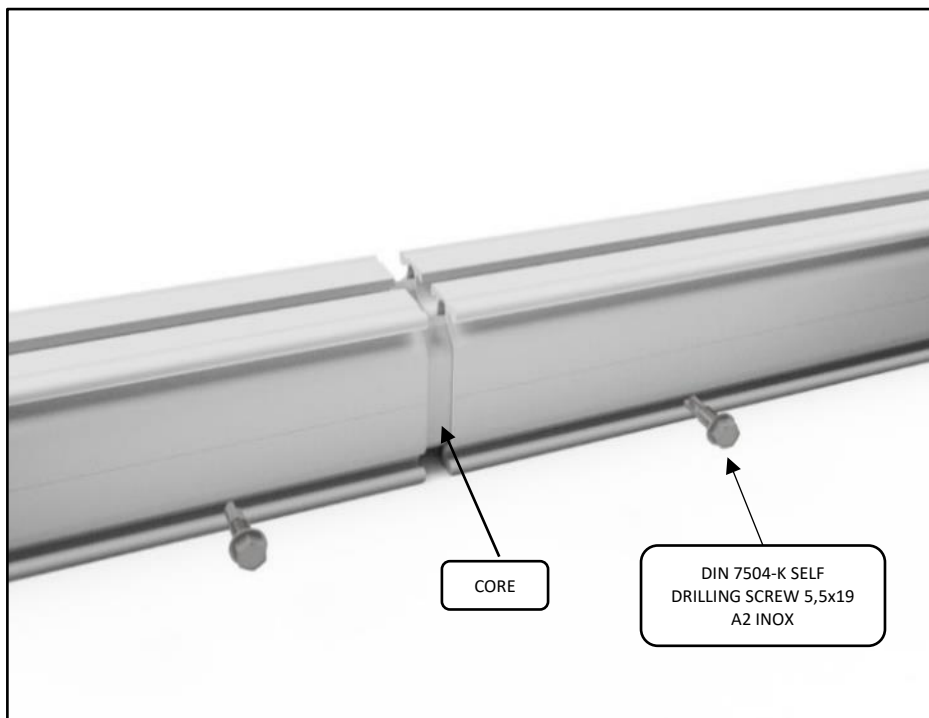

DETAIL B

Secure each core by using 2 Self-Drilling Screws 5,5x19mm, with one screw on each side of the Beams.

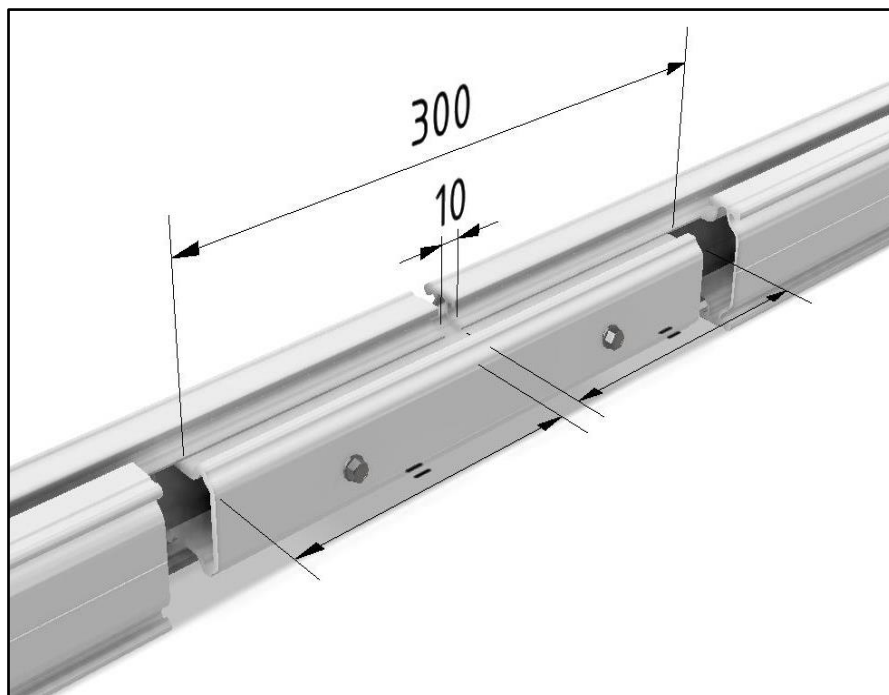

In case of a project that the panels start from the lowest point without a front elevation, requires to drill the Inclined Beams and assembly them with the Base plate.

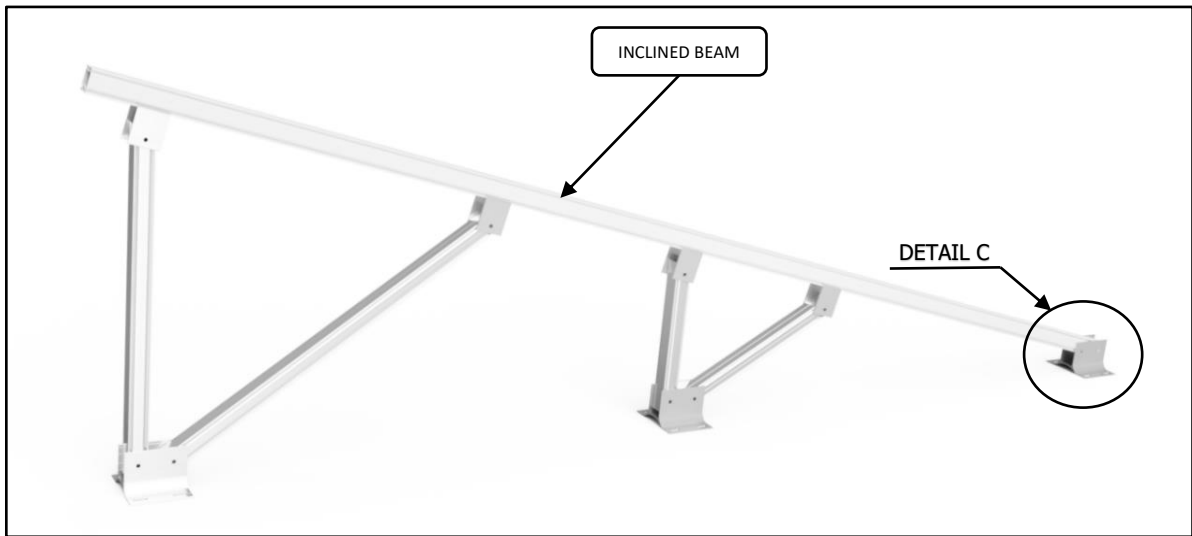

Drill Holes in Inclined Beams at designated location.



Assembly the inclined beam with the base plate using M10x80 screw and M10 Flange Nuts.

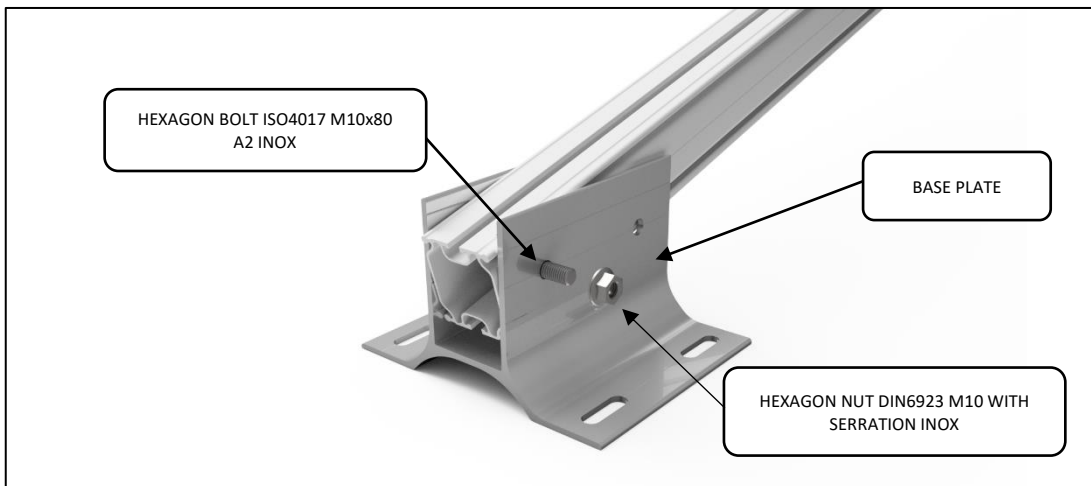

DETAIL C

➤ **Mounting Connectors with inclined beam**

Mount the inclined beam connectors onto the inclined beam using Hammer Head Bolt M8X22 with EPDM and Hex Nut M8 with Serration (2 pcs. per connector). Follow the instructions provided in the shopping drawing for precise placement.

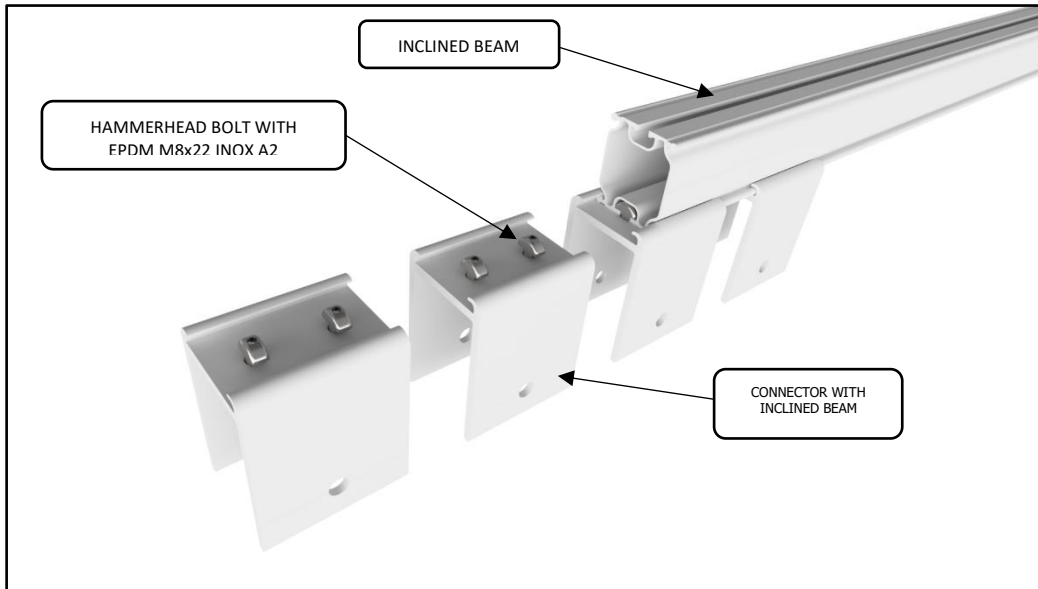

Tighten the bolts and nuts securely, ensuring that the connector is firmly attached to the inclined beam.

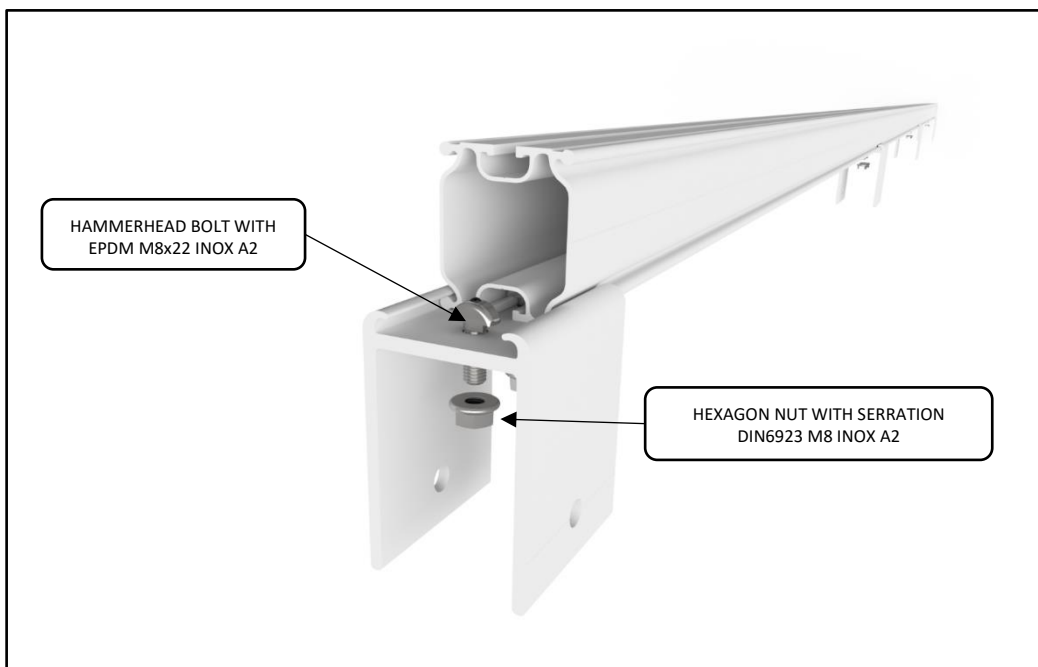



➤ **Mounting Brackets with Base Plates and the Inclined Beam**

Due to variations in project requirements, the standard lengths of Brackets may need to be adjusted accordingly. This adjustment process may involve cutting the Brackets to the required lengths as specified in the project drawings and drilling holes as necessary.

Cut the Brackets referring to the project drawings to determine the required lengths. Carefully measure and mark the piles before cutting them to ensure accuracy. Utilize appropriate cutting tools to achieve clean and precise cuts.

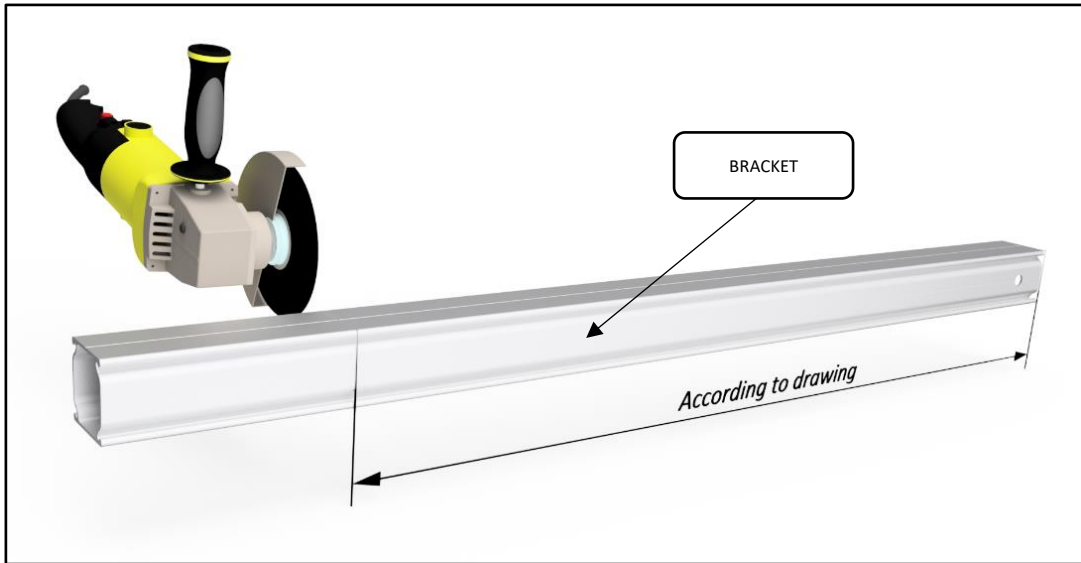

Drill holes in the Brackets at designated locations to facilitate connection with the components.

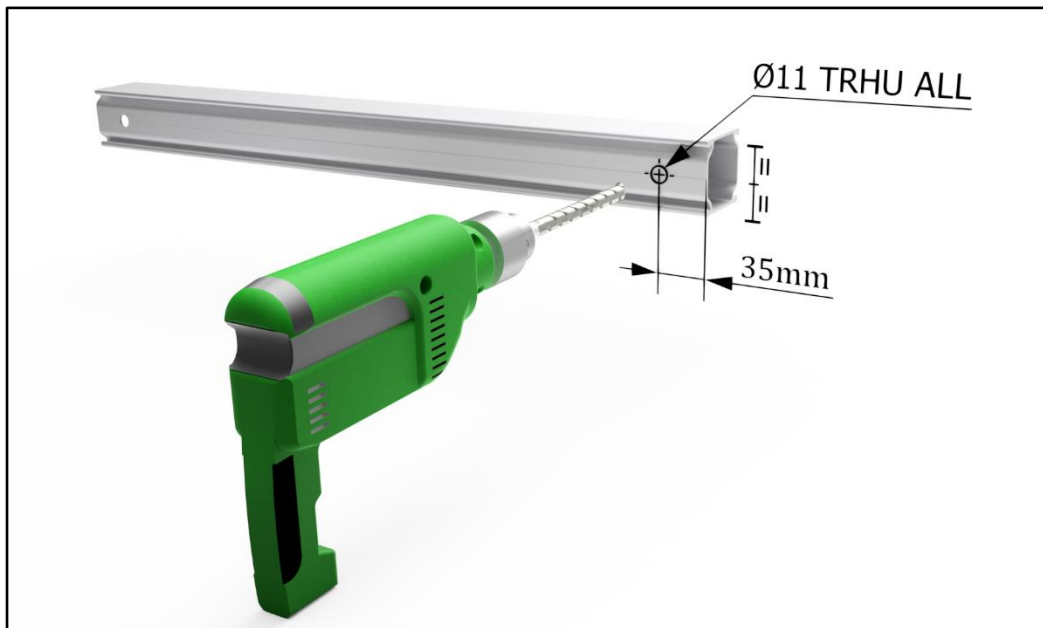

Attach the Brackets to the base plates using Hex Bolt M10x80 and M10 nuts with serration, following the instructions outlined in the shop drawing. Place the bolts and nuts in the designated holes without tightening them initially. This allows for adjustments to be made to the inclined beams' angles later in the installation process.

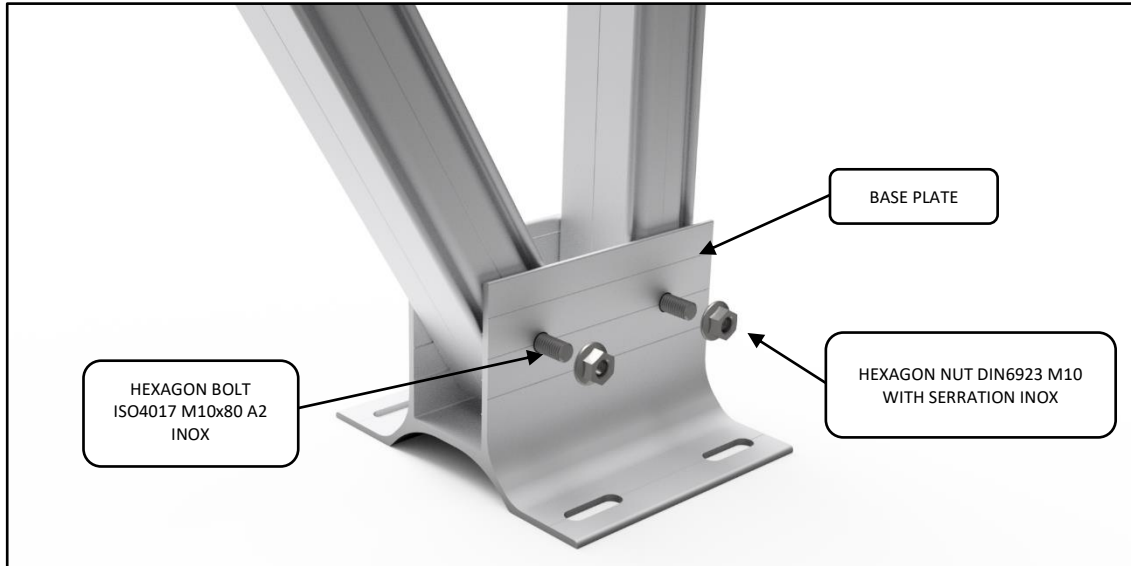

Securely connect the connectors of the inclined beam with each bracket using one bolt M10x80 and one M10 nut with serration. Ensure that the connections are tightened appropriately to maintain structural integrity.

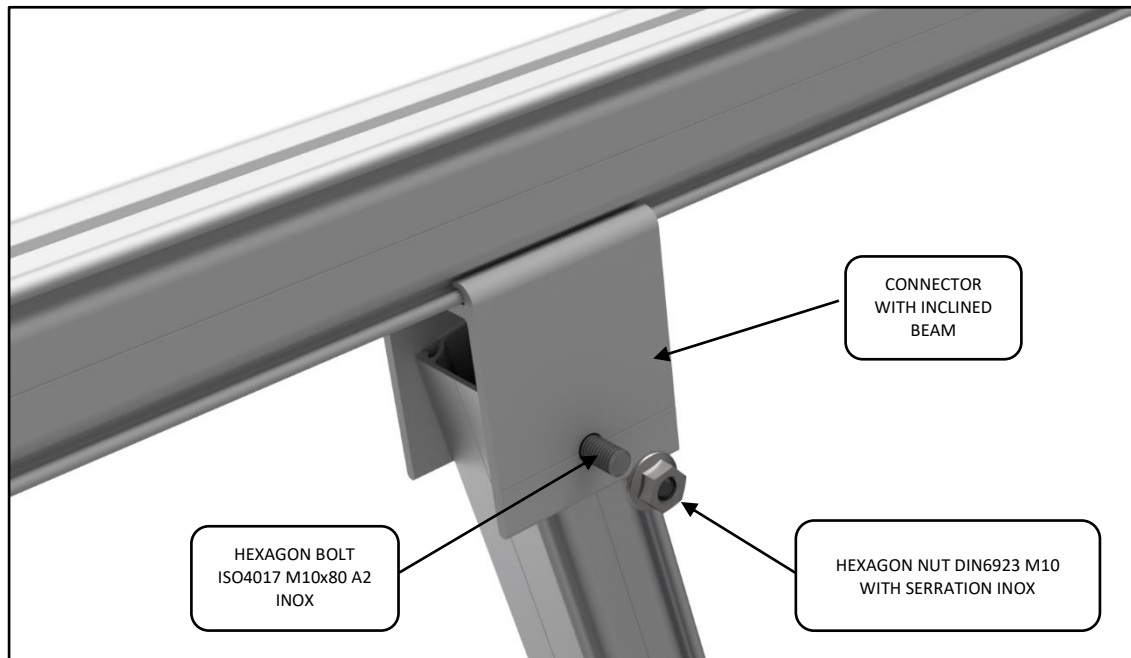

After all connections are made, carefully inspect all bolts to ensure they are tightened to the correct torque specifications. This step is crucial for the safety and stability of the mounting structure.

➤ **Placing purlins on inclined beam**

Place the purlins at the appropriate distances, according to the manufacturer of the PV module.

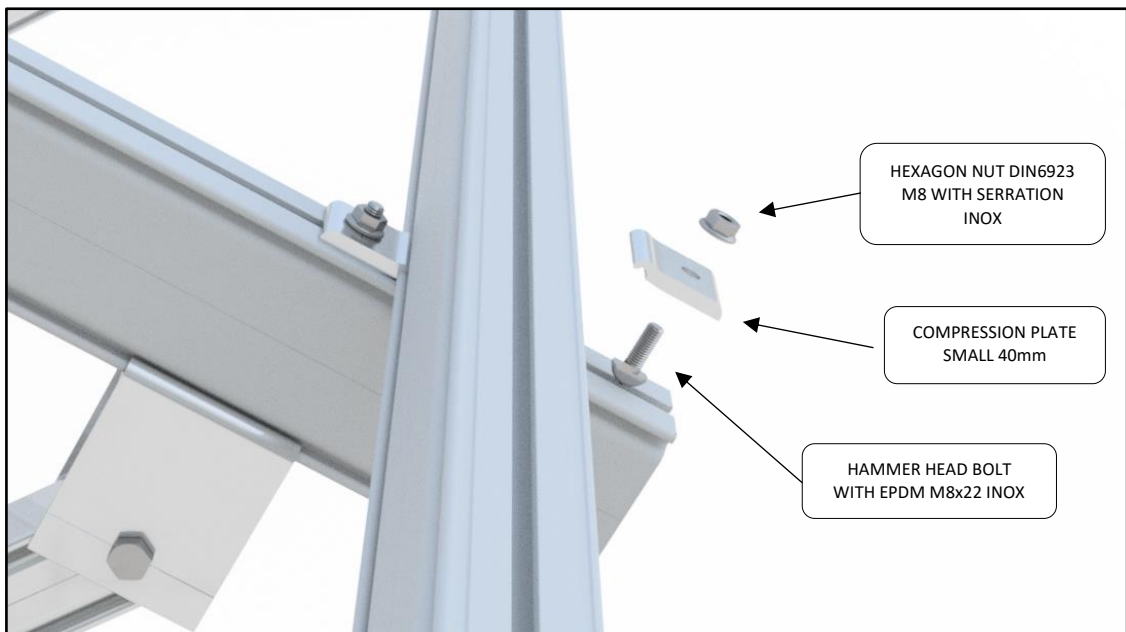
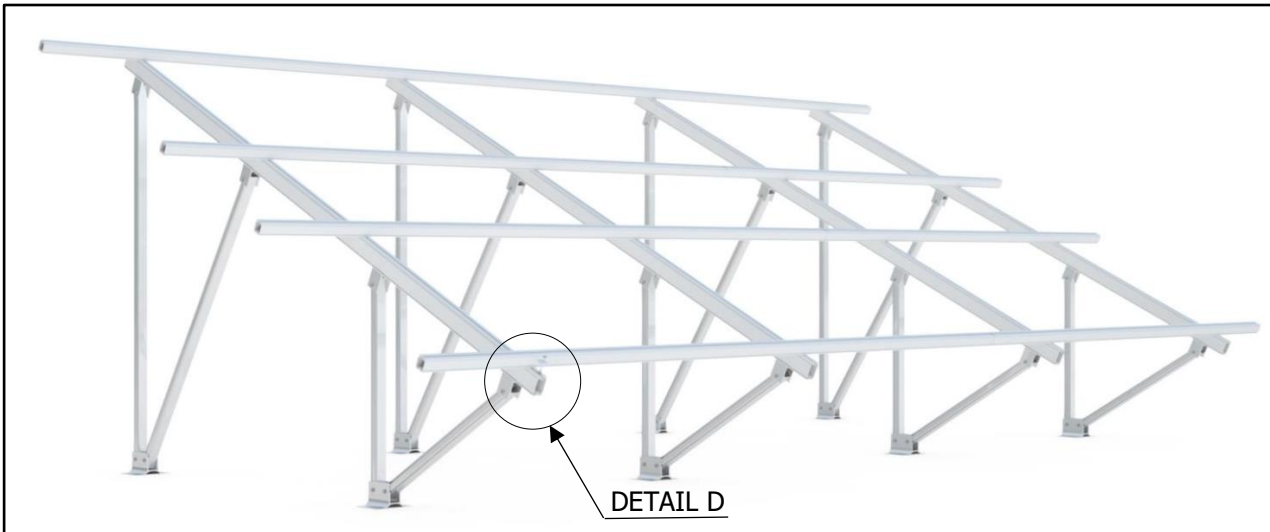

DETAIL D

➤ **Connecting Purlins Together Using Cores**

After bases installation, are placed. In their meeting point, the connection should be done with the help of core accessory. Core is used to connect two identical profiles, while helping in the absorption of thermal expansions due to temperature changes.

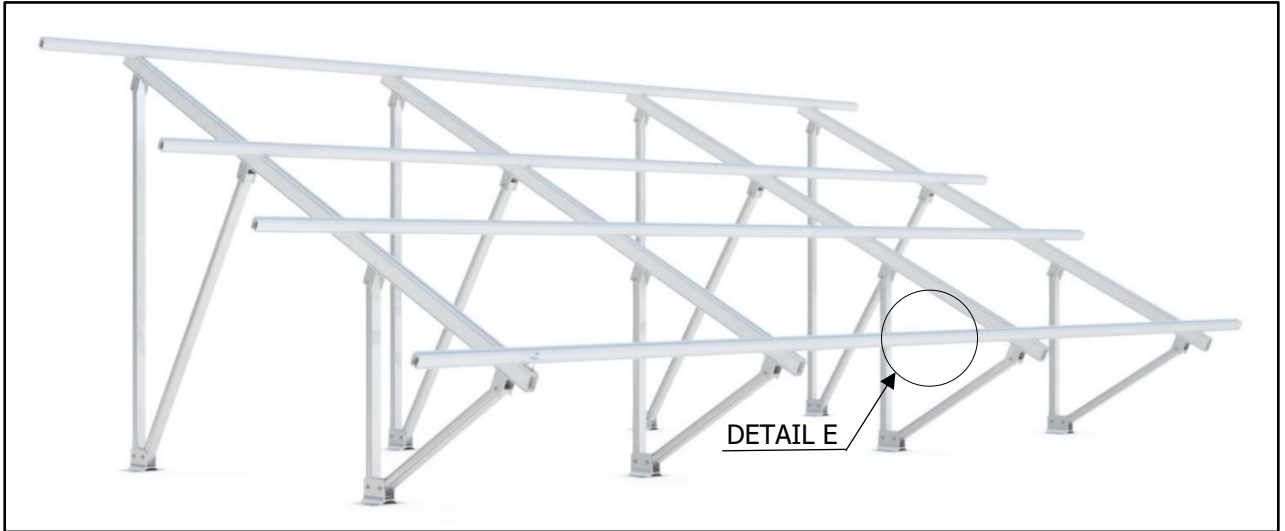

Place the core in the 2 successive profiles and mount with 2 self-drilling screw.

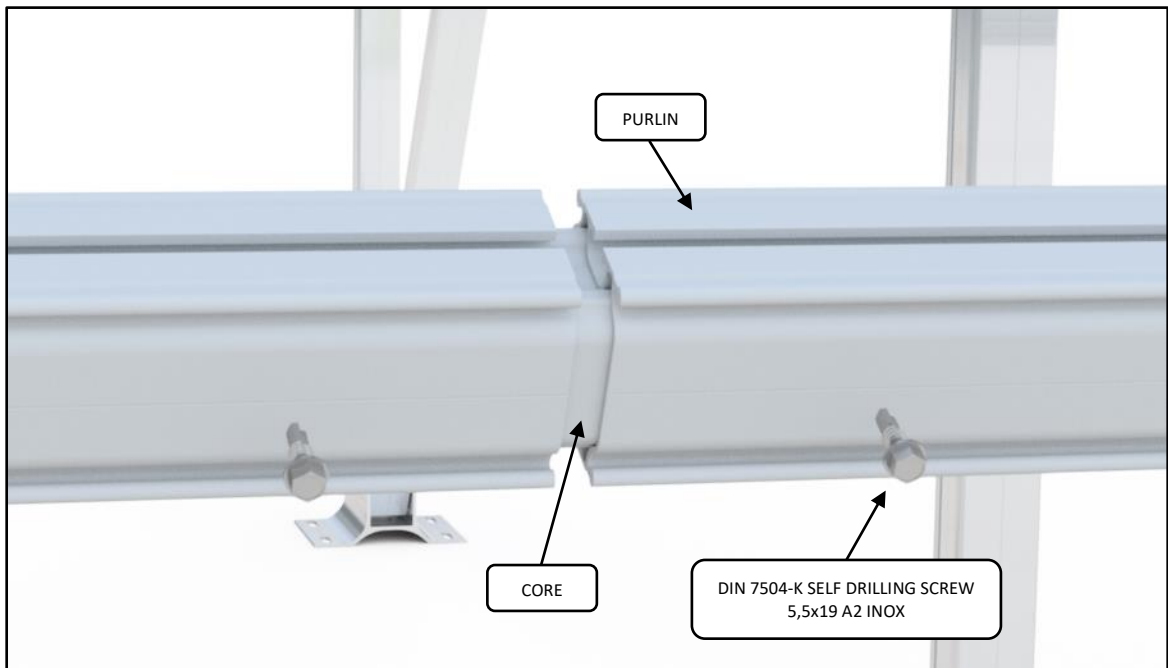

DETAIL E

Place the core in the 2 successive profiles and mount with 2 self-drilling screw, with one screw on each side of the Beams.

Secure each core by using 2 Self-Drilling Screws 5.5x19

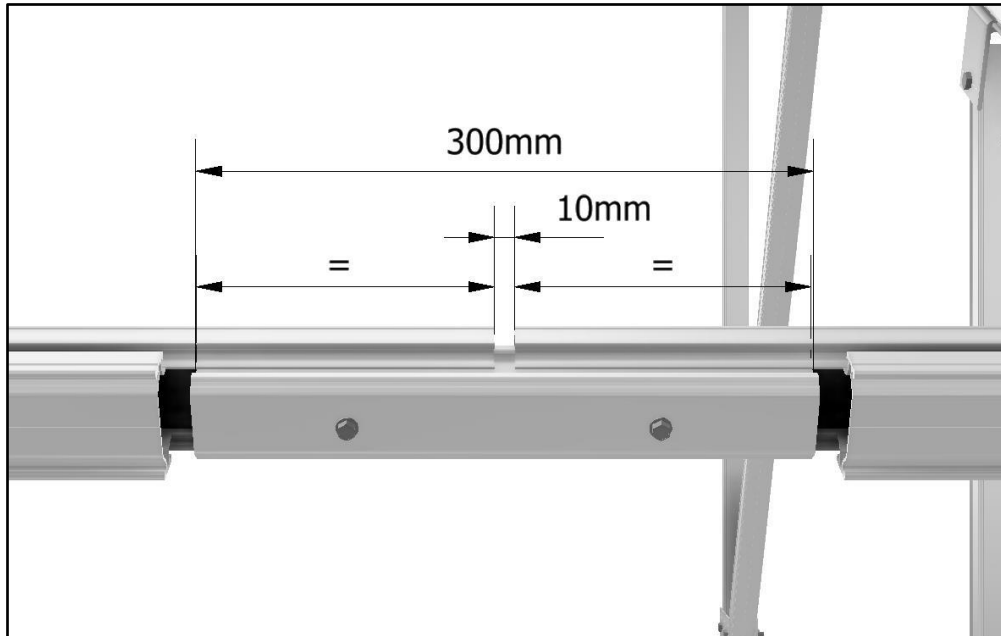

## ➤ Mounting panel

The process for fixing the photovoltaic (PV) modules with clamps after fixing the purlins is as follows:

1. Gather all necessary tools and materials, including the PV modules, clamps, and any other necessary hardware.
2. Locate the purlins that have already been fixed in place.
3. Place the clamps loosely on the purlins, making sure that they are spaced evenly and positioned in a way that allows them to be used to secure the PV modules.
4. Begin with the placement of the PV modules on the purlins. Start by positioning the end clamps at the start and end of a line, and then place the middle clamps at all other locations along the line.
5. Secure each PV module in place by tightening the clamps, making sure that each module is securely fastened to the purlins.
6. Repeat the process of placing and securing PV modules along each line, making sure that each module is properly aligned and that all clamps are tightened securely.
7. Inspect the entire installation to make sure that all components are securely attached and that there are no gaps or other issues.



Mount the edge panels onto the purlins using an End Clamp, an M8 Allen Bolt of specified length, a M8 serrated lock washer, and a T-Slot Aluminum Nut.

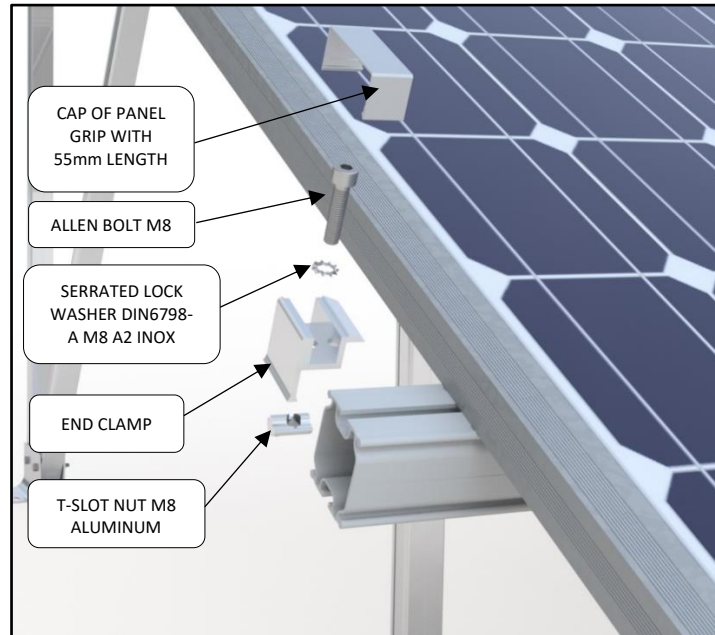

DETAIL F

To mount two intermediate panels on the purlins, use a Mid Clamp, an M8 Allen Bolt of specified length, a M8 serrated lock washer, and a T-Slot Aluminum Nut.

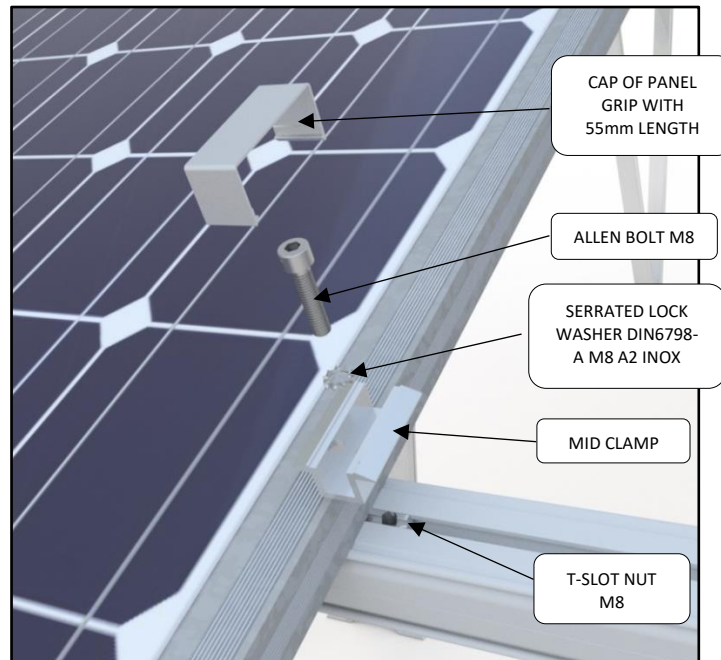

DETAIL G

Note: It is important to follow the manufacturer's specifications and guidelines for the installation of the PV modules, clamps, and other components, as these will vary based on the specific application and requirements. Failure to properly install these components can result in damage or failure of the system.

➤ **Placing end cups for Purlins and Inclined Beams**

Install the yellow plastic caps on the end of the rails, both on the purlins and the inclined beams

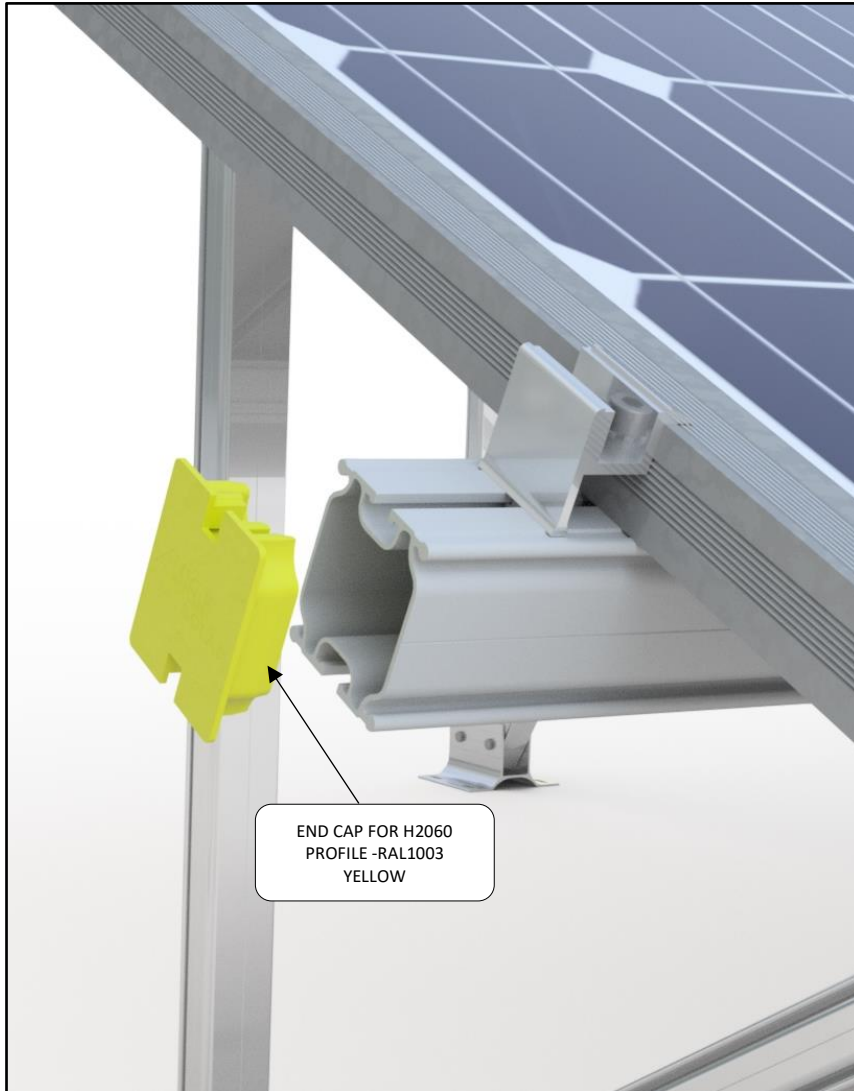



➤ **Mounting Windshields (optional)**

After finishing the installation of a table, place the windshields at the back of structure.

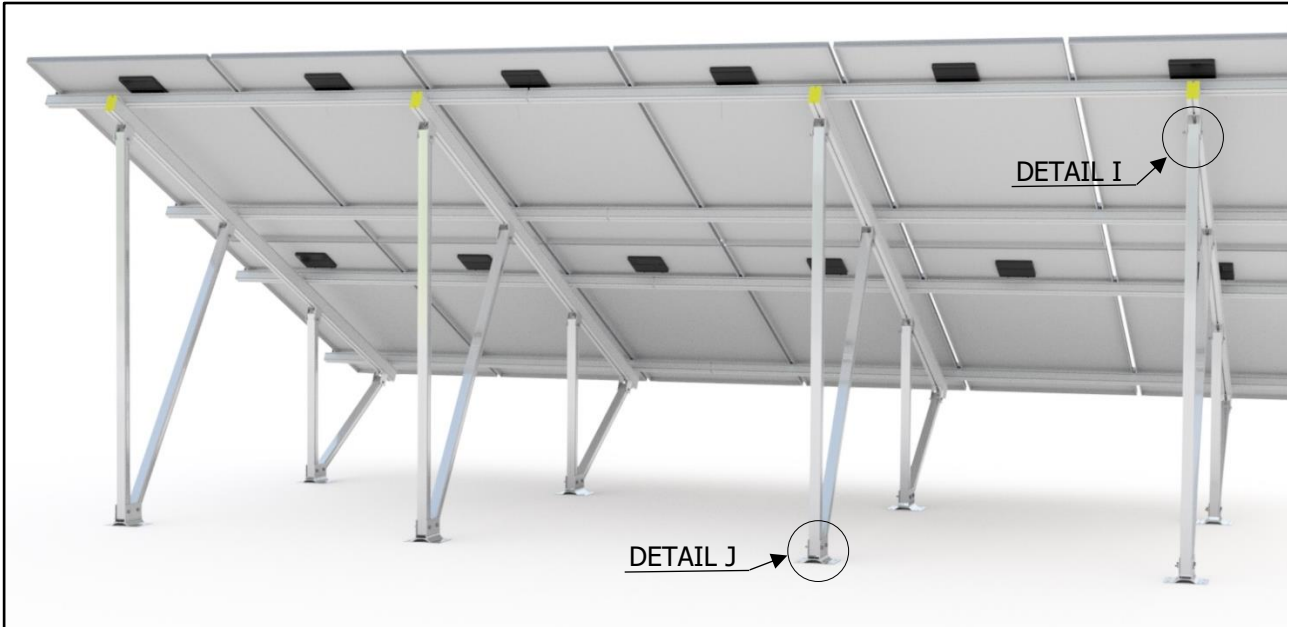

We drill a hole with a diameter of 9mm through the center, 100mm away from the edge.



DETAIL I



DETAIL J

The measurement of the holes can be done.

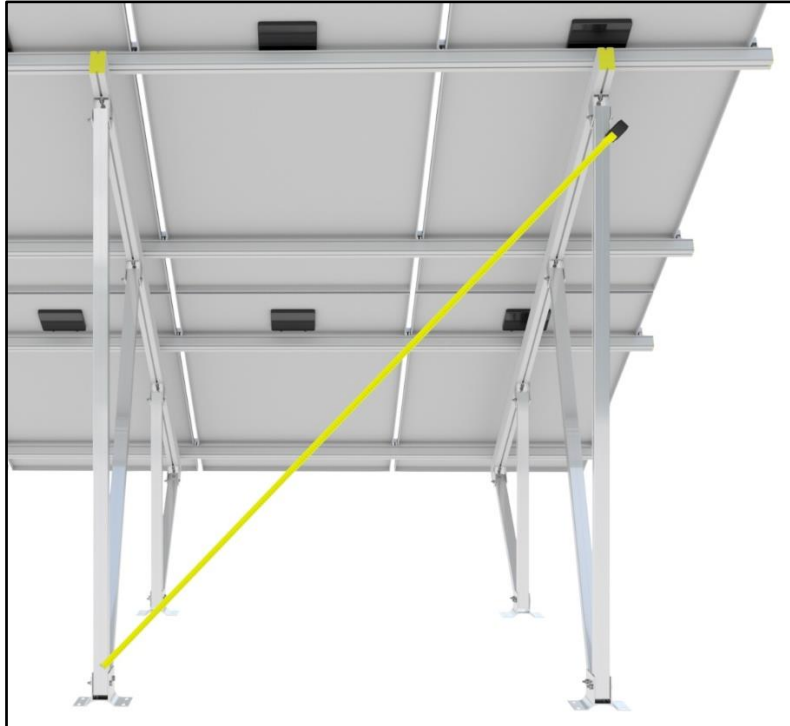

And then we drill the aluminum profile windshield. The holes have a diameter of 9 millimeters. The hole from the edge of the profile should be greater than or equal to 30 millimeters.

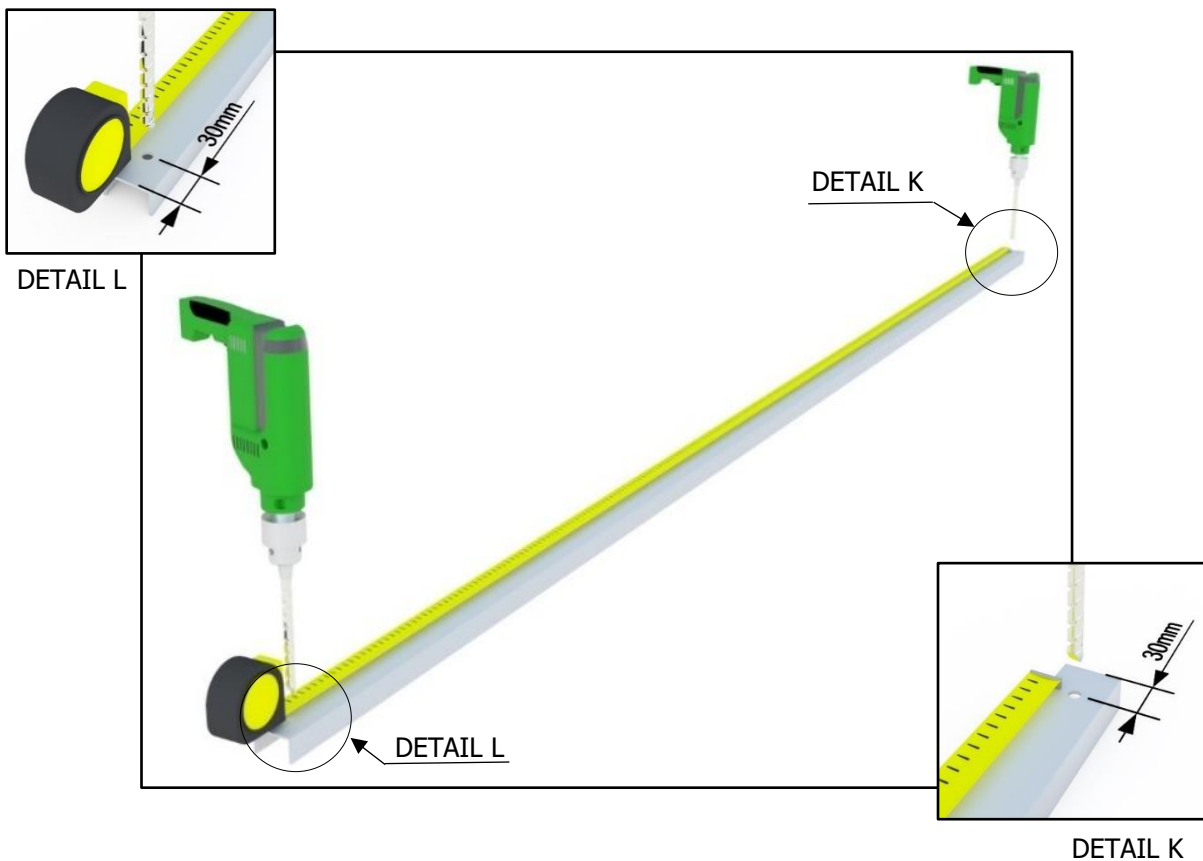

We place profile windshield in the column and secure it with the hexagon bolt M10x70 and hexagon nut M10 with serration.

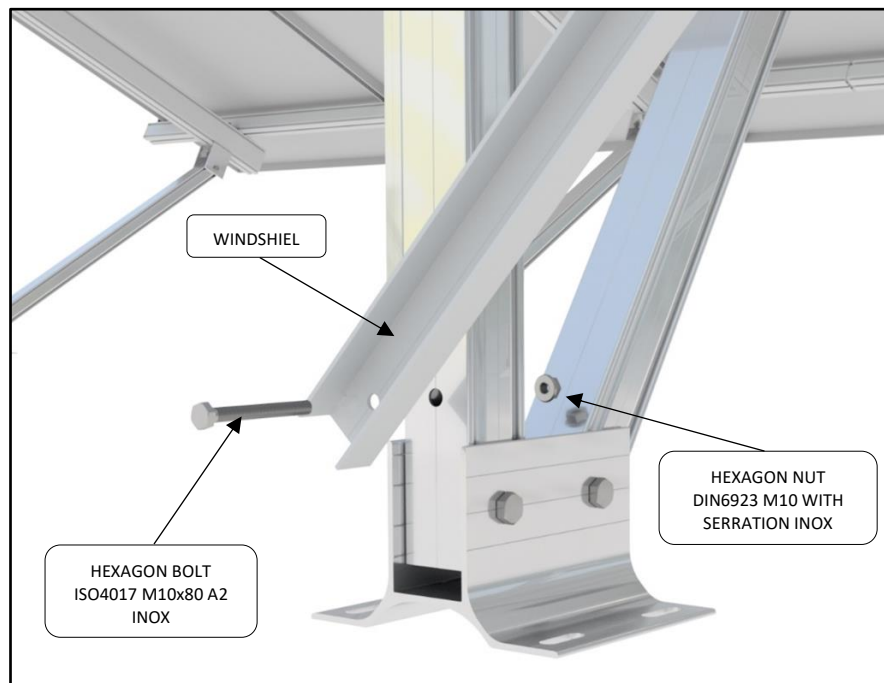
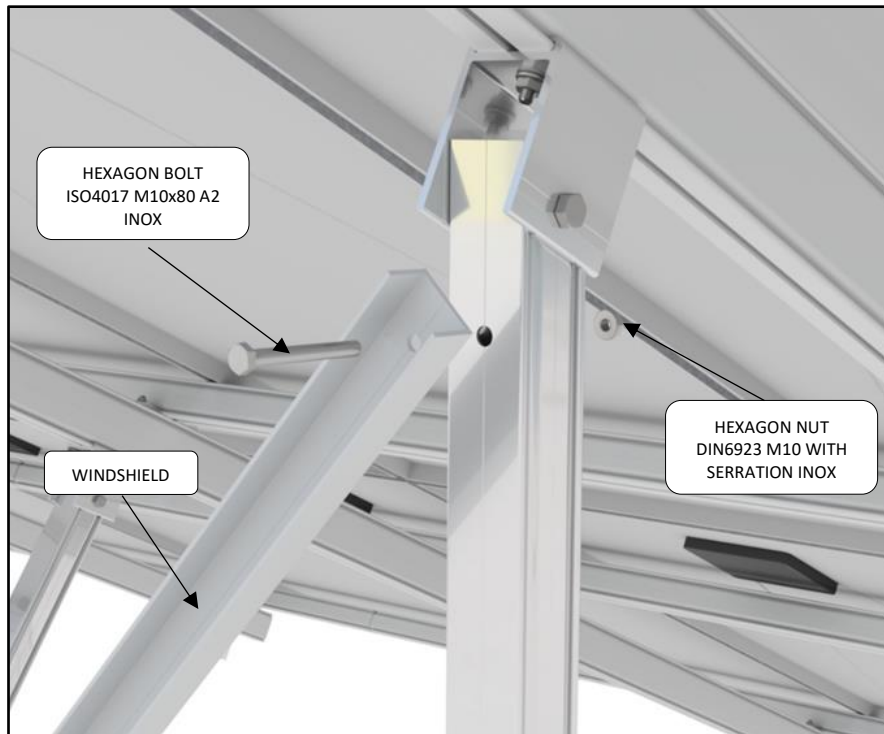

A complete installation with windshields.

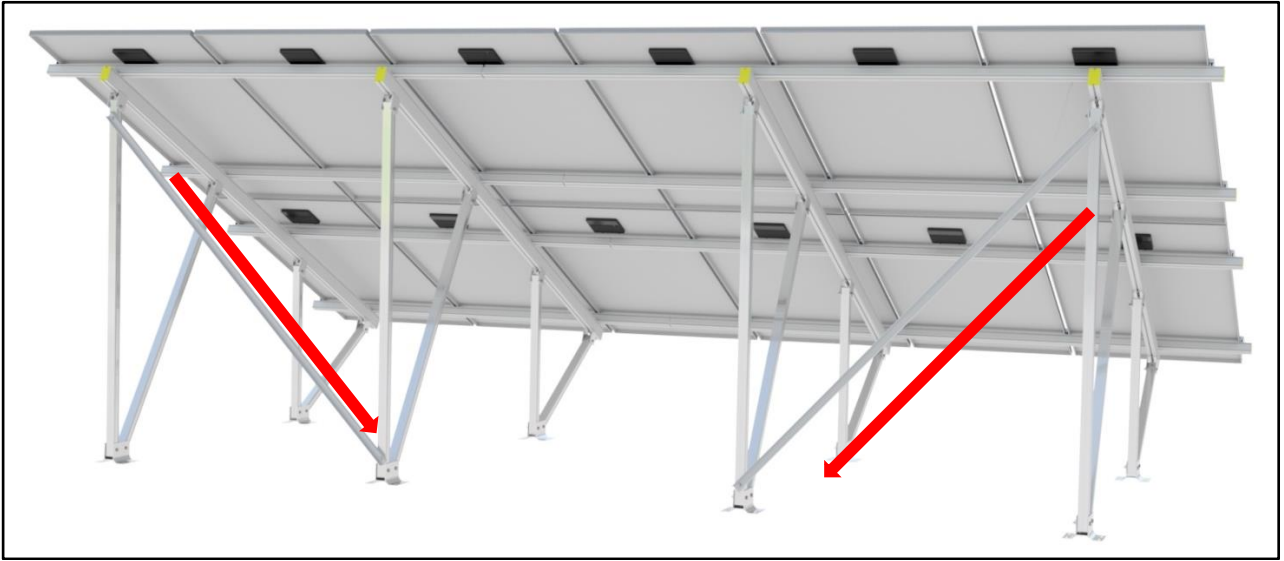

## C. MAINTENANCE

*The PV mounting structures of ALUMIL S.A are designed in accordance with the European Standards (Eurocode 1, 3, 9) and do not require any special attention. ALUMIL also offers certified aluminum PV mounting structures made from durable aluminum alloy (Al 6005T6).*

*However, regular maintenance is recommended to maintain the high quality and longevity of the structures.*

*During site inspections, it is advisable to pay close attention to areas such as joints and holes. Specifically, the following checks are recommended:*

- Inspect bolted joints annually and replace them if bolt corrosion is detected.*
- Periodically check the torque of bolted joints (every 1-2 years).*
- Verify the torque on panel clamps every 6-9 months or after severe weather conditions to ensure the installation and torque settings remain accurate. Torque specifications can be found in the installation manual.*
- Inspect aluminum and plastic components for any deformations and replace any deformed parts as needed (every 2 years).*
- For locations close to sea level (<150m), it is important to clean the structures with water (no pressure) to prevent salt corrosion (annually).*
- If snow accumulates, the panels must be cleared within 2 days of being fully covered to avoid freezing. Remove the snow without allowing it to freeze.*